

## BWG Micro Cyclone Jet Installation Instructions

### IMPORTANT SAFETY INSTRUCTIONS READ AND FOLLOW ALL INSTRUCTIONS SAVE THESE INSTRUCTIONS

1. Cut a hole in the spa wall for the jet.
  - a. Cut a 2.125" diameter hole in the spa wall.
2. Position the gasket on the jet body, see Figure 1.

#### Note

Silicone is required with the flat gasket design. Silicone is optional for use with the "L" gasket design.

3. Insert the jet body through the hole in the spa. Make sure the gasket is flat and not crimped around the hole.
4. Place the compensation spacer on the jet body with the flat side of the spacer against the back of spa wall.
5. Thread the nut onto the body. The compensation spacer will center on the nut as it is tightened.
  - a. Be sure the plumbing ports are adjusted to the desired position and tighten the nut hand-tight.



#### CAUTION

Do not over tighten as this may cause damage to parts and leakage may occur. There should be plenty of room for the compensating ring to freely "float" as the nut is tightened. If this ring is obstructed in any way, it will lose its effectiveness resulting in excessive and unequal force on the sealing flange. This may cause damage to parts and leakage may occur.

6. Torque the nut to a maximum setting of 9 foot pounds. BWG has an installation tool for tightening the nut that is used with a customer supplied torque wrench. It can be ordered through BWG customer service.
7. Make the plumbing glue connections to the jet body. Be sure that glue is not allowed to run into the jet body.
8. Install the barrel assembly into the jet body by inserting and rotating the barrel until it snaps into place. It will rotate freely left and right to the stop.

#### Note

To remove the barrel assembly, rotate in a counter clockwise direction until it stops. Using additional force, continue to rotate the barrel assembly past the stop while pulling it out from the body.

Figure 1

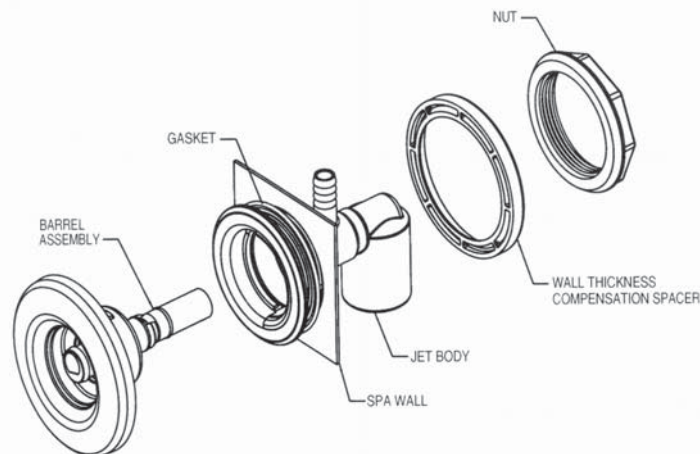

(cont. other side)

# BWG Micro Cyclone Jet Application Recommendations

This state-of-the-art Micro Cyclone Jet technology features several unique and patent pending installation features.

## **Thoroughly read and understand these application recommendations before installing this jet.**

While installation is simple, there are many variables with each spa manufacturer's process that are beyond our control. Therefore we *STRONGLY RECOMMEND* that every OEM thoroughly test the application of this jet before using it on their production line.

The unique design feature of the Micro Cyclone Jet creates a seal at the front (acrylic side) of the spa.

There are advantages to sealing at the front of the spa.

- Acrylic is an optimal sealing smooth surface, much better than fiberglass.
- Potential leaks, or fiberglass delamination can be prevented by preventing possible water migration.

To fully gain these advantages, the mounting surface must be flat!

Each OEM should carefully survey every jet recess. A flat sealing area 4 inches in diameter is required. Ensure the cove which is formed at the bottom of a jet recess is fully drawn down and not allowed to drift into the jet sealing area. The hole must be drilled in the center of the recessed area. The sealing area must be consistently flat.

Examine the drilling process. The hole must be drilled no larger than 2.125".

Do not allow the hole saw to "work or walk" during drilling! This could produce a hole that is off center, or not round. Also, the walls of the hole could be incorrectly cut on an angle. Ensure the hole saw is sharp. A dull saw will create excessive heat. Excessive heat will cause the acrylic to curl up at the edge of the hole, leaving a burr. Any of these conditions will impede the sealing process.

Following these recommendations will provide trouble free operation of the cyclone jet. If you have application questions, please call (714) 384-0384.

## **SAVE THESE INSTRUCTIONS**